

THIS DRAWING AND ITS DESIGN AND ITS DETAILS ARE THE PROPERTY OF DCI CORPORATION AND SHALL NOT BE COPIED IN WHOLE OR IN PART WITHOUT WRITTEN CONSENT OF DCI CORPORATION. ALL RIGHTS OF DESIGN AND INVENTION ARE RESERVED.

REVISIONS				
ZONE	REV.	DESCRIPTION	DATE	APPROVED
	A	INITIAL RELEASE	7/14/17	SPH

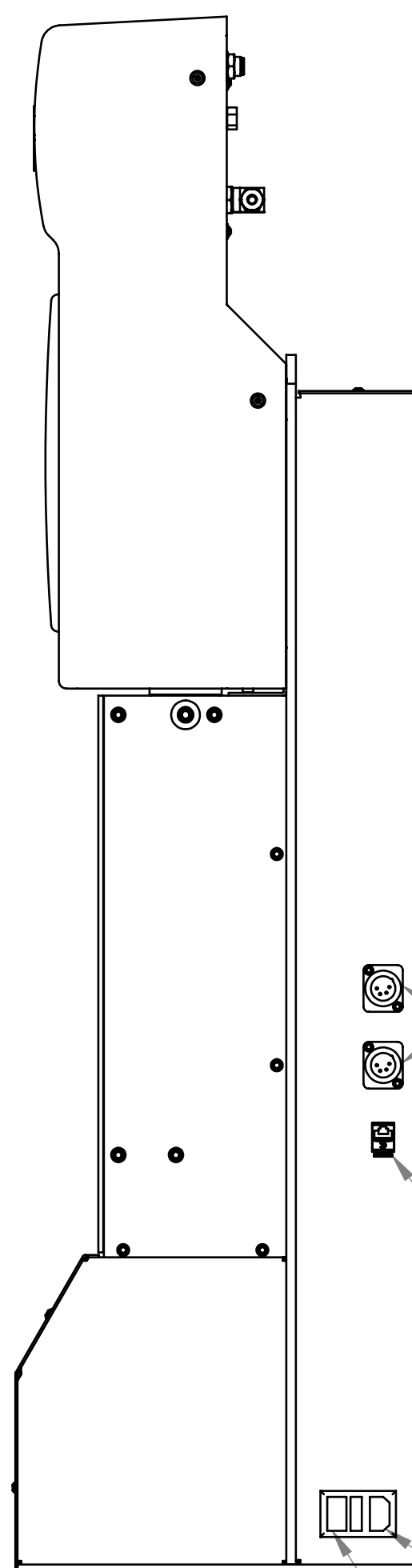
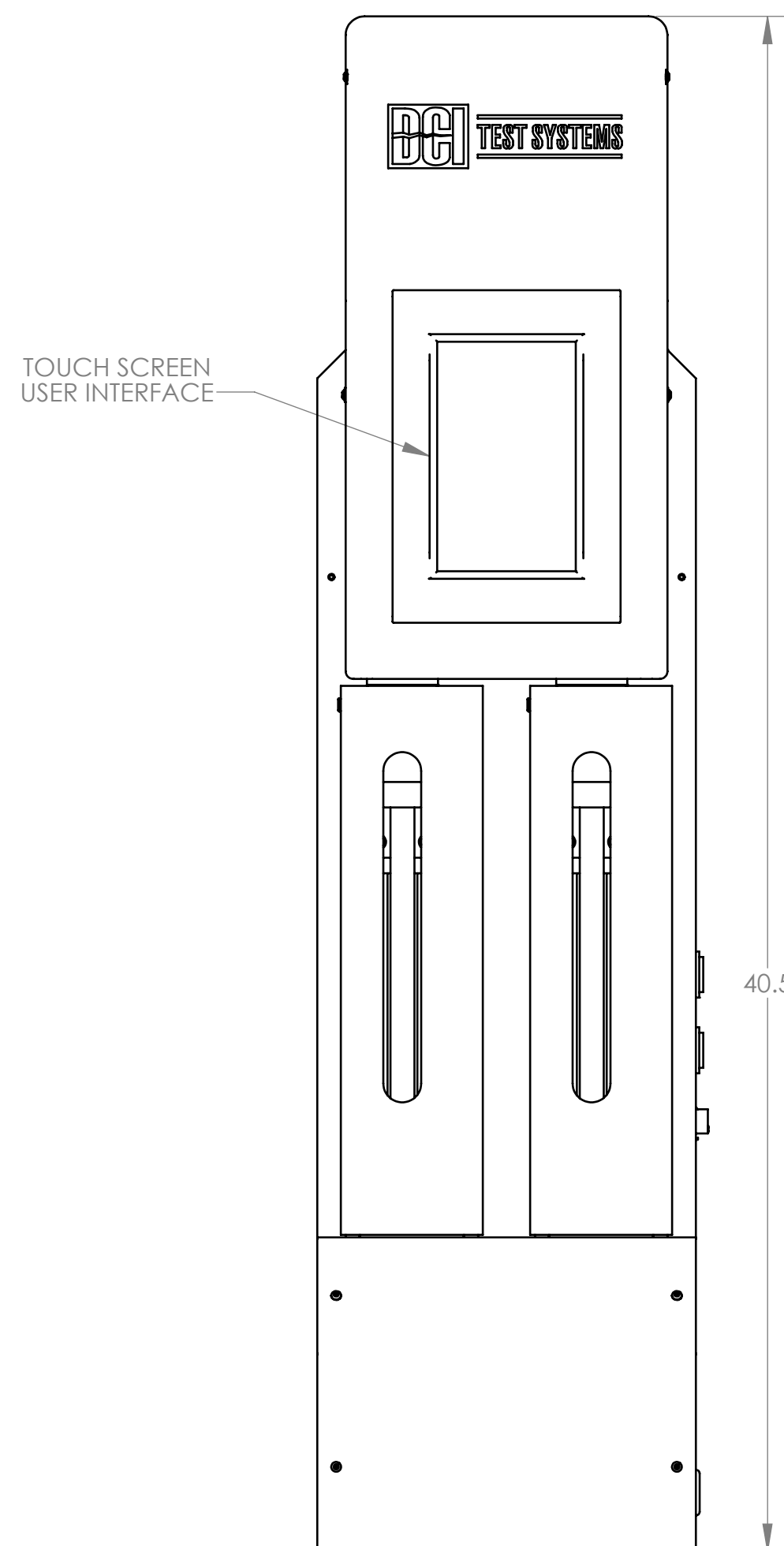
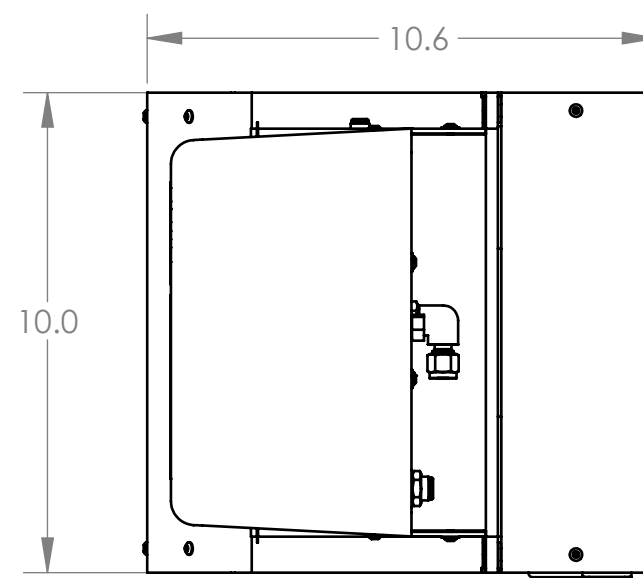

AIR IN 1/4" TUBE PUSH TO CONNECT CONNECTION

FLUID OUTLET PORT
USER SPECIFIED
CONNECTION TYPE

FLUID INLET PORT
USER SPECIFIED
CONNECTION TYPE

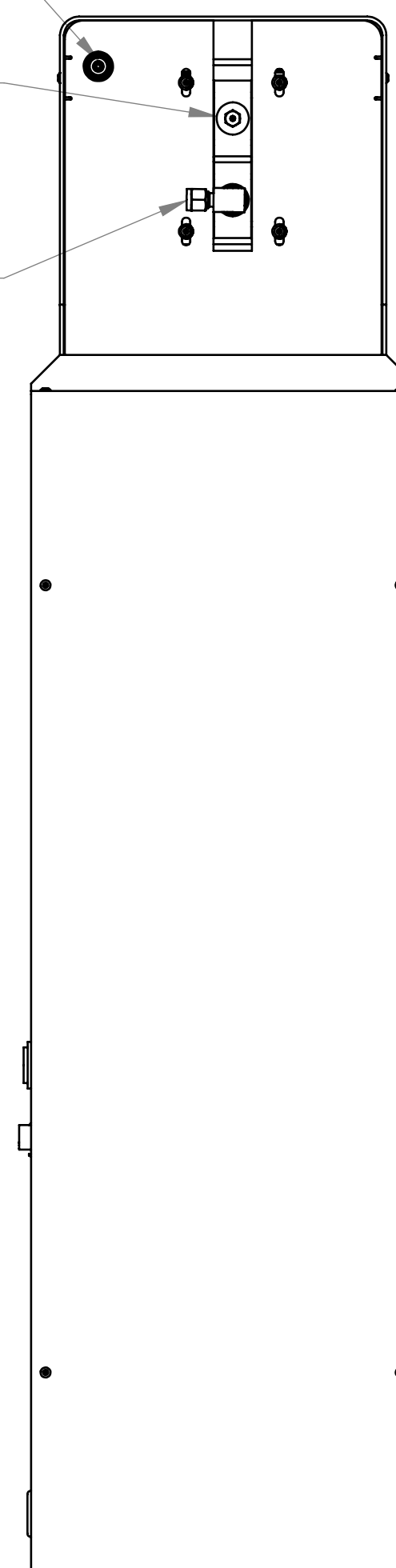

APPROVED	-	-	
ENGINEER	-	-	
CHECKED	-	-	
DRAWN	DWW	7/13/17	
UNLESS OTHERWISE SPECIFIED:			DATE
BASIC DIM.	DECIMAL	FRACTIONS	
	2PLCS	3PLCS	
UNDER 6"	± 0.02	± 0.010	± 1/32
6" TO 24"	± 0.03	± 0.020	± 1/16
OVER 24"	± 0.06	± 0.030	± 1/8

DCI TEST SYSTEMS

TITLE: **SERIES 16 DUAL CONFIG. OUTLINE DRAWING**

SIZE DWG. NO. **4640** REV **A**

NOT TO SCALE REF. ASS'Y: SHEET 1 OF 1